



The ERMML3-01B is a Large Fixed TV Mount 42"-90" TV weighing 135 lbs of wood stud, concrete, and 100 lbs drywall. This mount has a profile of 1.7" and can be level-adjusted on one bracket. Easy three-step installation. A universal hardware bag is included in the package. The ERMML3-01B locking mechanism is a spring lock block with magnetic adjustable cords, allowing them to be discreetly concealed in the TV, regardless of its size. ERMML3 is UL-tested and certified.

Features

- Fits 42" to 90" TVs. Holds up to 135 lbs on wood stud & concrete wall and 100 lbs on drywall respectively.
- The industry-leading design allows effortless TV positioning regardless of size and weight.
- 1.7" low profile brings your room a clean look.
- Pull cord lock allows easy and reliable locking or unlocking of your TV.
- The +2° level function ensures the television is perfectly level for optimal viewing.



TV Compatibility

VESA
100x100 - 600x400 mm

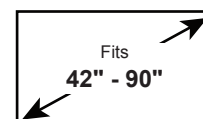

WARRANTY: 5-Year

Product Specifications	DIMENSIONS (W x H x D)	PRODUCT WEIGHT	LOAD CAPACITY	FINISH	AVAILABLE COLORS
	17.1" x 31" x 9.1" 435mm x 786mm x 230mm	9.1 lbs. 4.12 KG	135lbs. (wood) 100 lbs. (drywall) 61 KG	Powder Coating	Black

Product Dimensions

TV INTERFACE

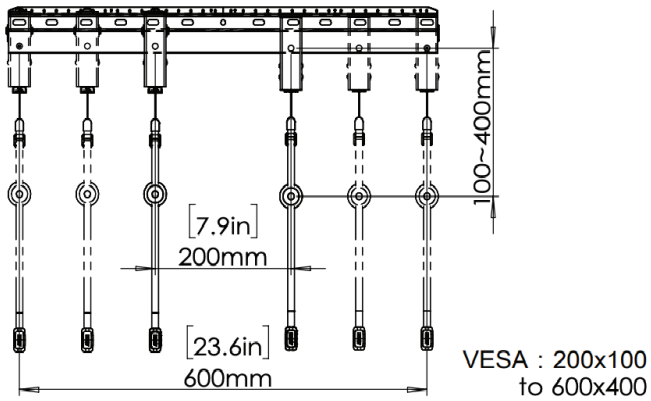

TOP VIEW

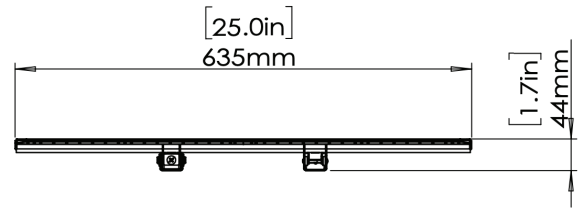

WALL PLATE

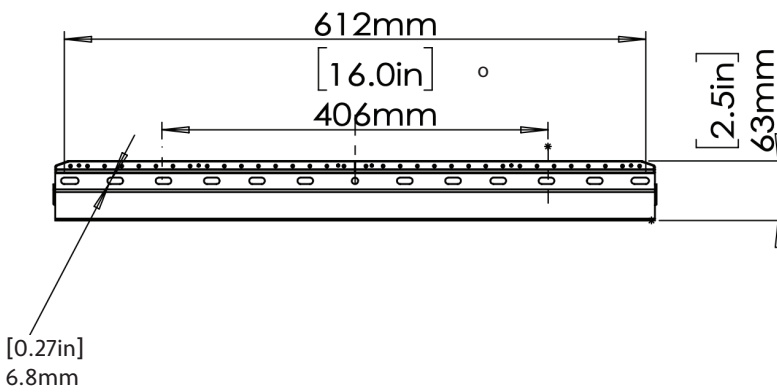

SIDE VIEW

