



ERMLX2-01B Extra Large Fixed TV Mount Designed to fit TVs from 65" to 115" and supporting up to 225 lbs on wood studs and concrete, or 110 lbs on drywall, this mount offers unparalleled stability and versatility. Its ultra-low profile of just 1.2" ensures a sleek and unobtrusive appearance, making your TV the space's centerpiece. Installation is a breeze with the ERMLX2's intuitive three-step process, allowing you to set up your TV quickly and efficiently. The innovative quick-connect locking mechanism with magnetically

### Features

- Fits TVs from 65" to 115" and supports up to 225 lbs on wood studs and concrete, or 110 lbs on drywall.
- An ultra-low profile of just 1.2".
- Intuitive three-step process, allowing you to set up your TV quickly and efficiently.
- Magnetically adjustable pull tabs ensure your TV is securely attached and can be discreetly concealed behind the screen, maintaining a clean and tidy look regardless of the TV's size.



### TV Compatibility

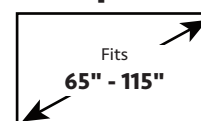
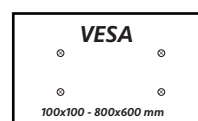

**WARRANTY:** 5-Year

Product Specifications	DIMENSIONS (W x H x D)	PRODUCT WEIGHT	LOAD CAPACITY	FINISH	AVAILABLE COLORS
	34.3" x 24.8" 1.3"	9.8lbs.	225lbs.	Powder Coating	Black
871mm x 629mm x 33mm	4.4 KG	102KG			

## Product Dimensions

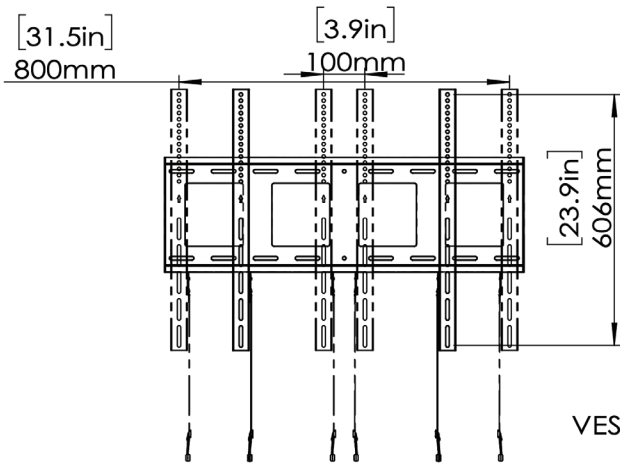

TV INTERFACE

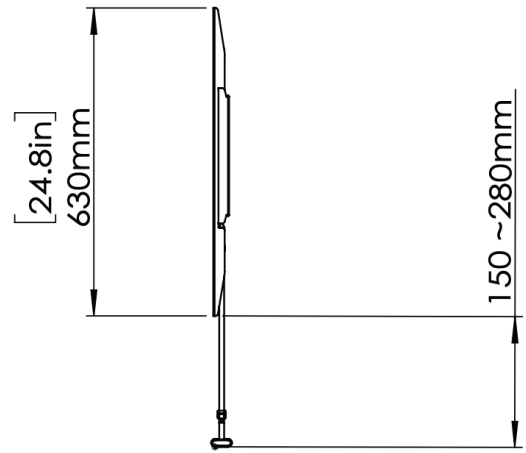

SIDE VIEW - TILTING

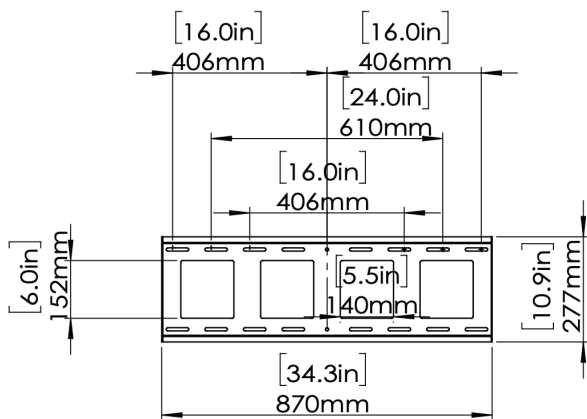

WALL PLATE

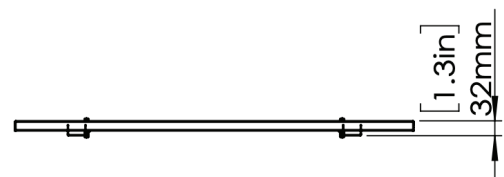

TOP VIEW