

TV INTERFACE

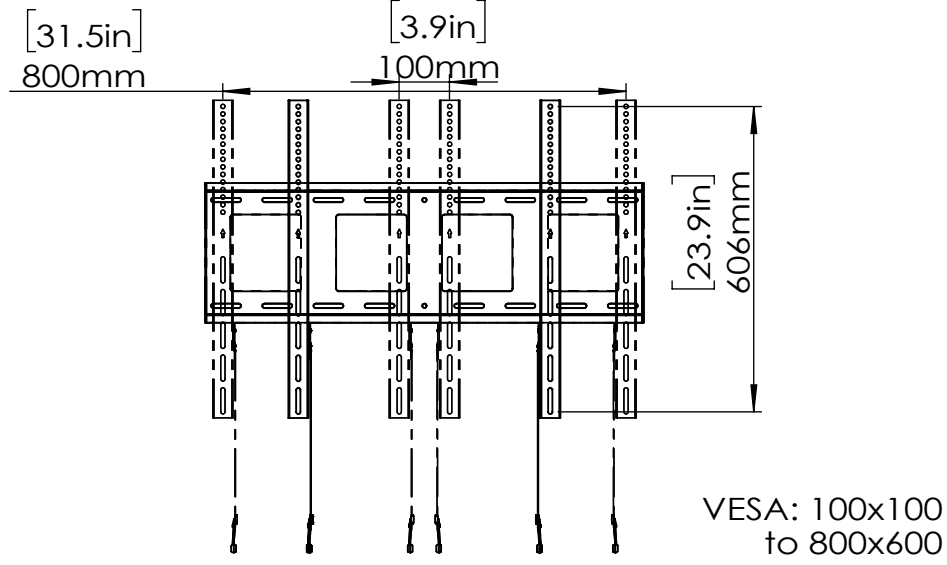

Technical Drawing

REV 00

Model Number	ERMLX2-01
Maximum TV Weight	225LBS
TV Size Range	65-115"
Net Weight	9.8 LBS
Gross Weight	11.3LBS
Product Dimension	34.3" x 24.8" x 1.3"

THE INFORMATION CONTAINED IN THIS DRAWING IS THE CONFIDENTIAL AND PROPERTY OF SHENZHEN BESTQI INNOVATION TECHNOLOGY CO.,LTD. ANY REPRODUCTION OR DISCLOSED WITHOUT THE WRITTEN PERMISSION OF BSQ IS PROHIBITED.

3-D View

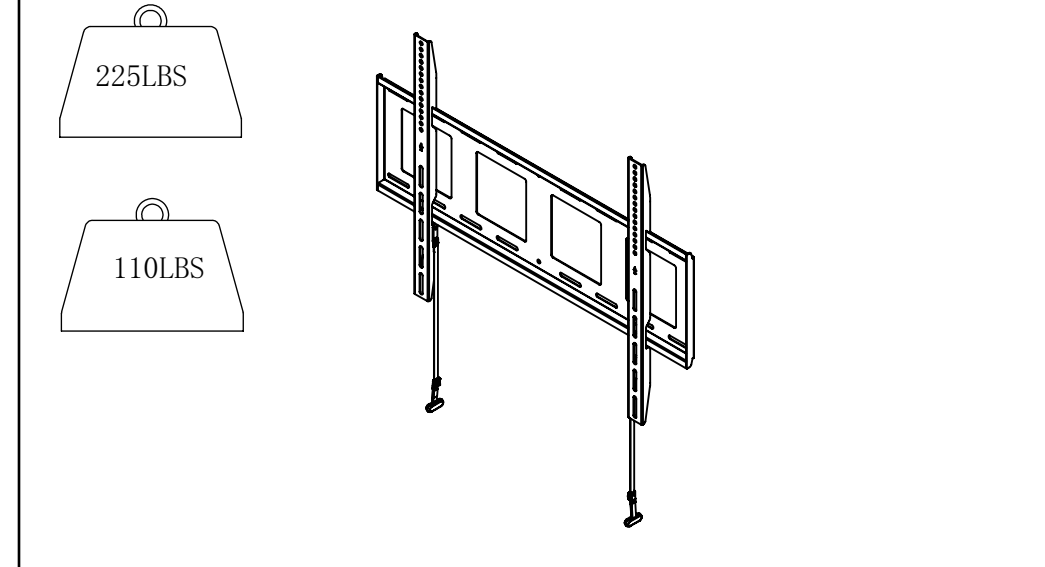

WALL PLATE

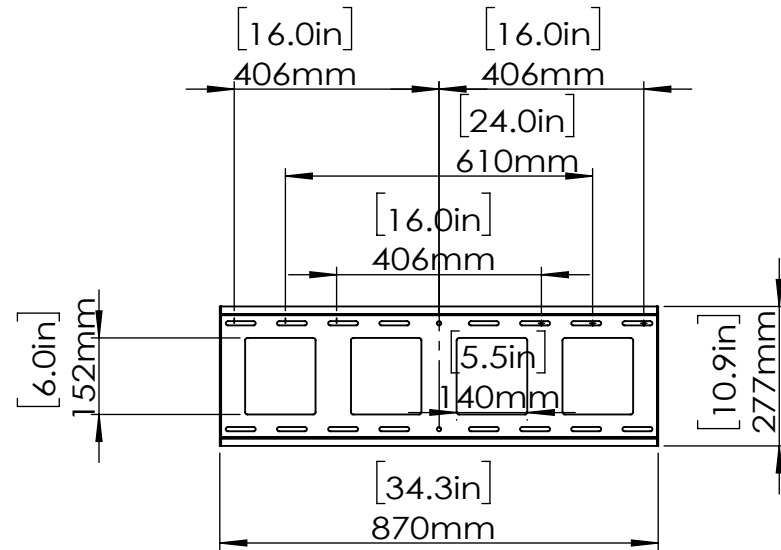

TOP VIEW

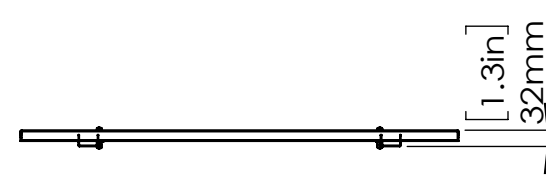

SIDE VIEW - TILTING

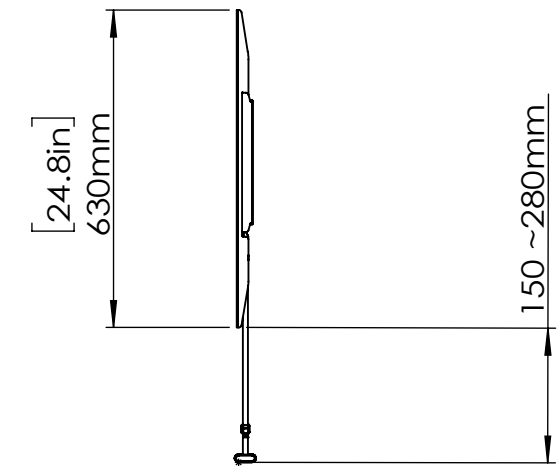

SHIP WITH

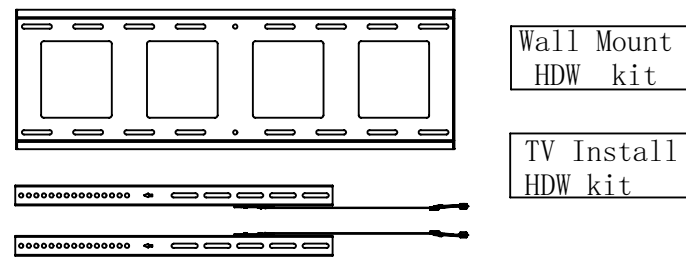

WALL MOUNT FOR 225LBS

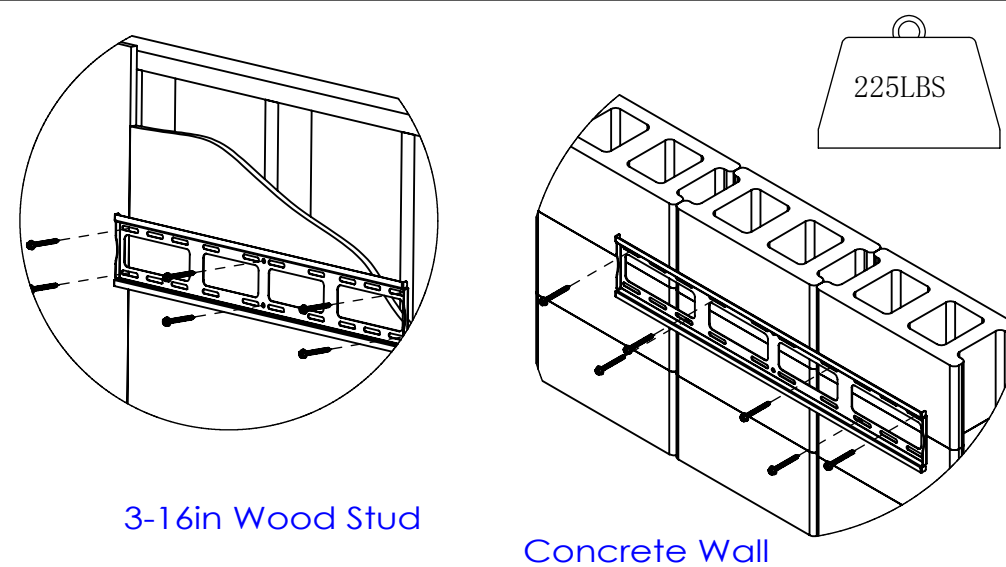

WALL MOUNT FOR 110LBS

