

TV INTERFACE

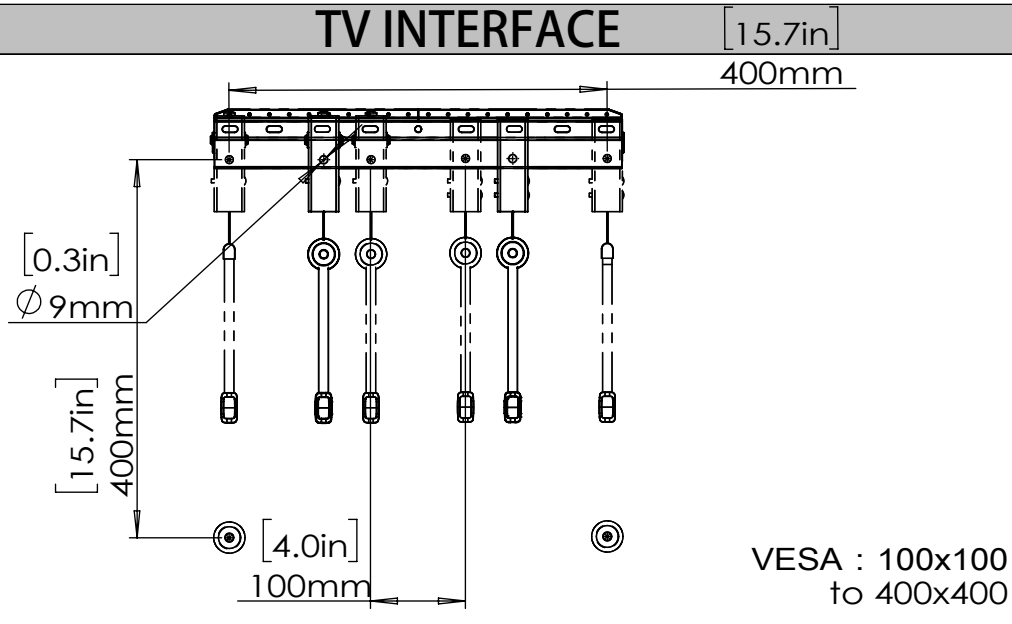

Technical drawing

REV 00

Model Number	ERMLM3-01
Maximum TV Weight	100 LBS
TV Size Range	19-65"
Net Weight	2.45 LBS
Gross Weight	3.61LBS
Product Dimension	17.1" x 4.3" x 1.7"

THE INFORMATION CONTAINED IN THIS DRAWING IS THE CONFIDENTIAL AND PROPERTY OF SHENZHEN BESTQI INNOVATION TECHNOLOGY CO.,LTD. ANY REPRODUCTION OR DISCLOSED WITHOUT THE WRITTEN PERMISSION OF PRIME IS PROHIBITED.

3-D View

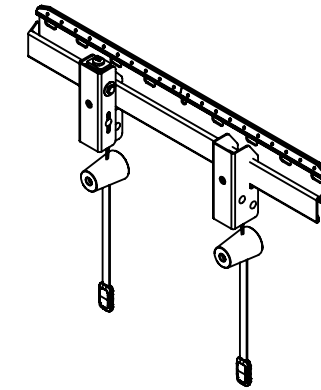

WALL PLATE

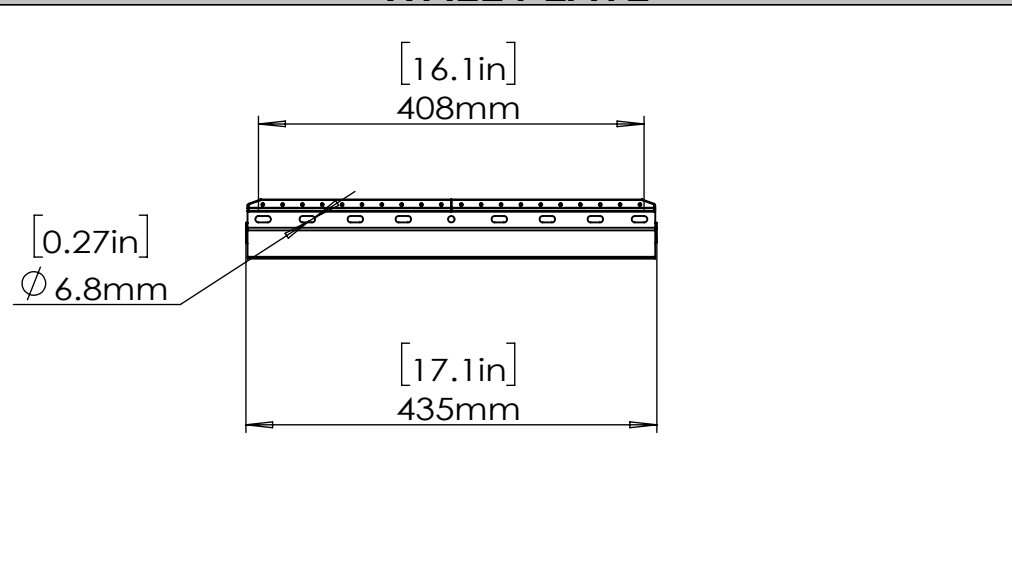

TOP VIEW

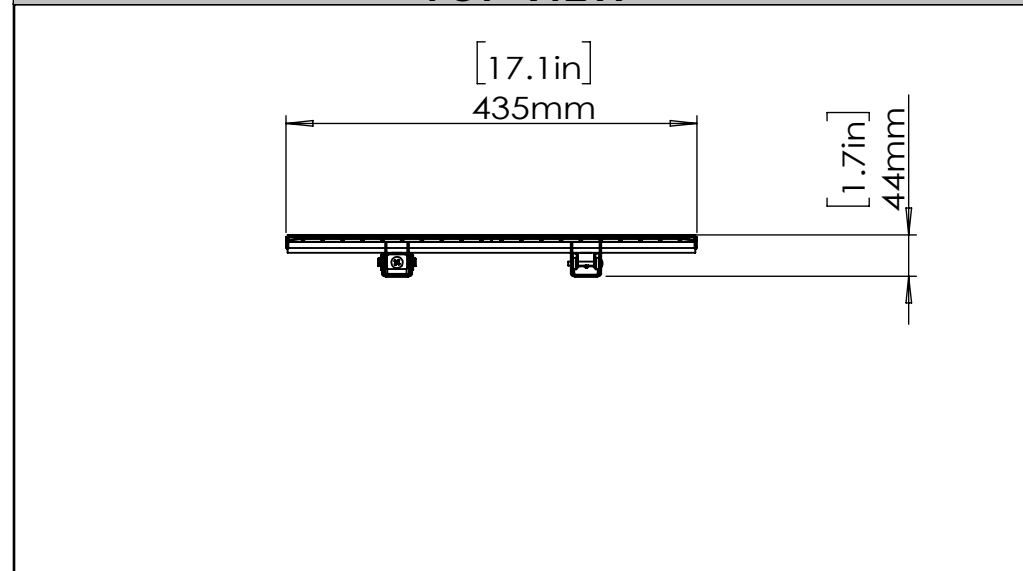

SIDE VIEW

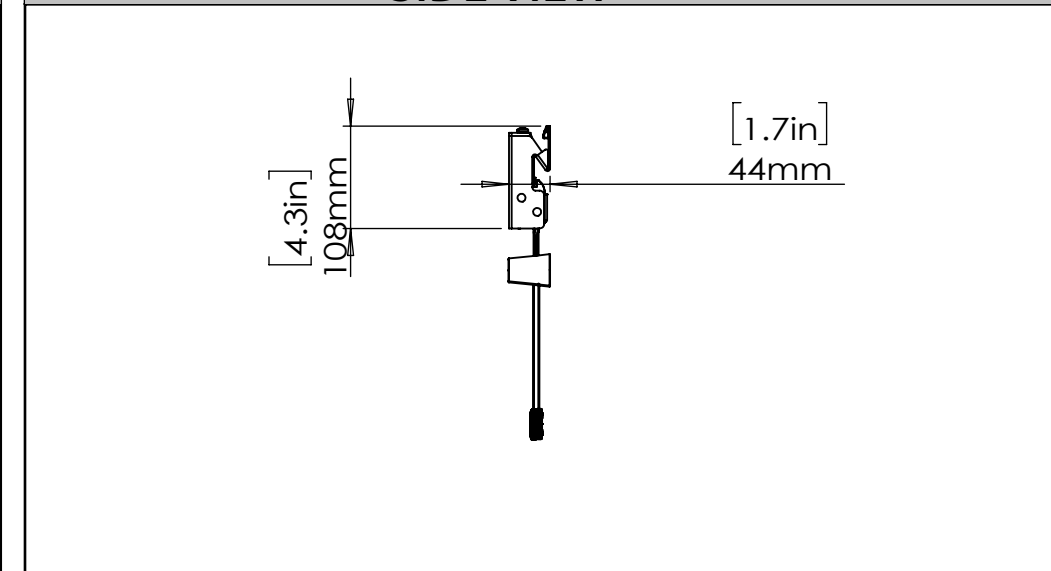

LEVEL ADJUSTMENT

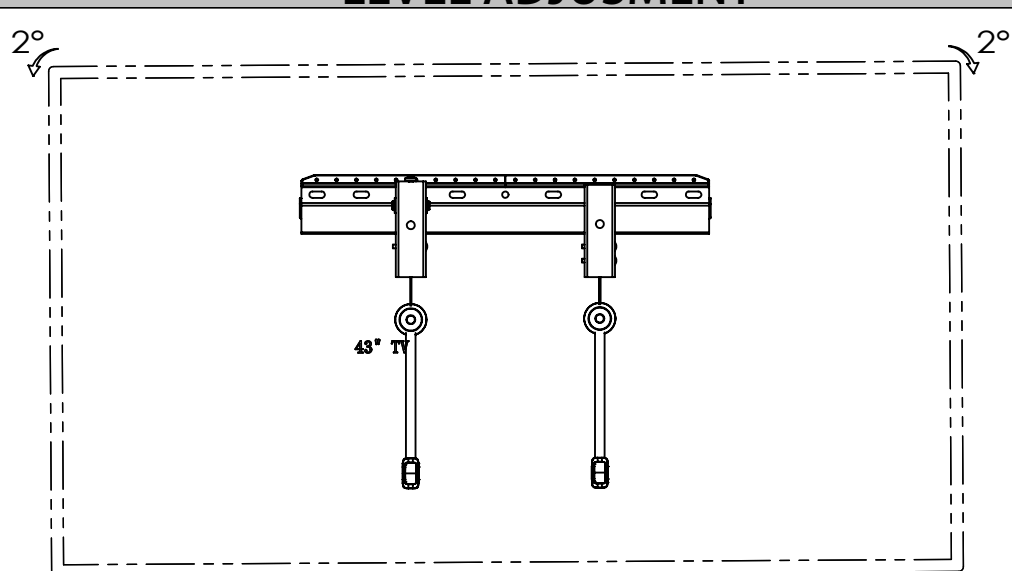

SHIP WITH

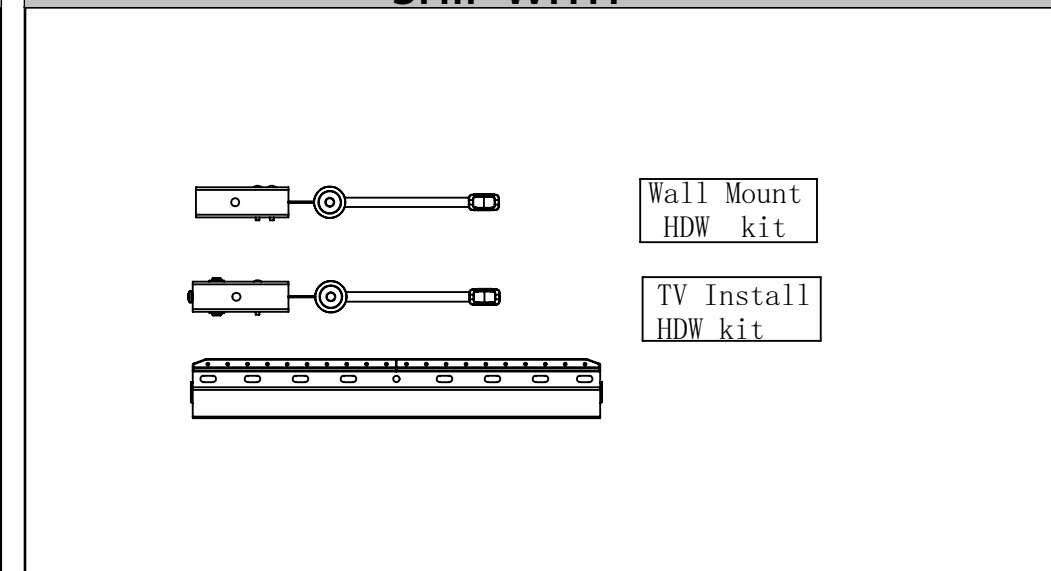

100 lbs(wood stud, concrete)
80 lbs (drywall)